



ECHOLINE®

ECHOLINE®

# LOW PRESSURE MONITOR



Prevents Unwanted Shutdown  
High & Low Alarm Settings  
UL 991

PRECISION  
SENSORS



## OVERVIEW

ECHOLINE® was designed in cooperation with a leading semiconductor manufacturer to prevent costly system shutdowns and reduce maintenance costs associated with low pressure monitoring of gas cabinet exhaust systems. ECHOLINE's Maintenance Mode feature prevents false alarms during system maintenance and balancing.

A customer defined time delay prevents false trips which can cause system shutdowns. "ECHO" (Electronic Circuit Health Output) diagnostics alert the user to loss of external power or internal electronics failure. Four ECHOLINE® units fit into the space of one old-fashioned gauge/switch.

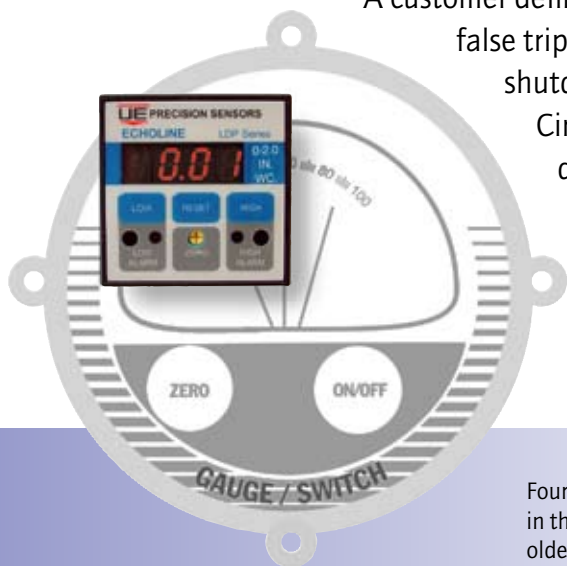

Four LDP switches will fit in the same space as one older gauge/switch

## APPLICATIONS

### STATIC PRESSURE APPLICATION

- Gas Cylinder Cabinets
- Gas Isolation Box (GIB)
- Mini Environments
- Wet Bench & Wet Station
- Chemical Dispensing
- Diffusion Furnace Scavenger
- Cleaning Hoods
- Glove Boxes
- Pump & Equipment Exhaust
- Supplemental Exhaust

### ECHOLINE® FULL SCALE RANGES

- 1" to 5" WC
- 1" to 5" WC
- 0.2" WC
- 0.5" to 1" WC
- 0.5" to 1" WC
- 0.5" to 1" WC
- 0.5" to 1" WC
- 1" to 5" WC
- 1" to 5" WC
- 0.5" to 1" WC

## FEATURES



LED display of process and alarm state

Alarm status indicator

Independently adjusted front panel zero adjustment

Independently-set low and high set points

- Conformance to S2-0200 and CE, complies with the requirements of **UL 991**
- Latching relay output with adjustable time delay
- "Maintenance Mode" to prevent false trips during ventilation system balancing
- LED status indication
- Self-diagnostics
- Adjustable time delay to eliminate false trips and unwanted system shut down
- Optional selectable display of WC" or Pascal

Front cover cleanroom image courtesy of Pentagon Technologies.

# SEMI S2-0200 SAFETY CONSIDERATIONS AND UL 991

**ECHOLINE®** was created using widely accepted best practices in an AS 9100 / ISO 9001:2000 quality environment. Components used in the design and production of ECHOLINE® have been selected for their time proven performance, availability and reliability. ECHOLINE® contains no moving parts that can wear out, or microprocessors that are susceptible to hidden software problems.

Centralized monitoring  
of multiple locations



## When Used To Provide Safety Interlock, Monitor Ventilation Or Optimize Exhaust, ECHOLINE® Features:

- Discrete all analog electronic components - no microprocessor
- Self-monitoring "ECHO" diagnostics
- Complies with the requirements of UL 991
- Fault tolerant design
- Maintenance mode
- User selected time delay
- Convenient interfacing with facility alarm system

## When Used To Monitor Non- Critical Ventilation, ECHOLINE® Features:

- Maintenance mode to prevent false trips during ventilation system balancing
- Optional non-latching relay
- Bright LED display of process pressure

## Operation

High and low limit alarms are independently set from the front panel. In normal operation, the LED display will indicate the sensed pressure and the High Limit/Low Limit LED status indicators will be green. When a preset limit is exceeded, the LED signals an alarm condition by turning red. After a customer selected time delay, the electromechanical relay contacts will be latched open and the LED display will flash the process pressure once every second. Manually depressing the reset button will cause the relay contacts to close if and when the process pressure is within set limits.

## Maintenance Mode

The "Maintenance Mode" option is a unique and convenient safety feature which allows the user to widen the alarm set points during system maintenance. By closing terminal circuits 3 and 4, using a key switch or password protected computer, the user can expand the limits to 5% and 95% of the range to continue monitoring and prevent false trips. Opening terminal circuits 3 and 4 immediately returns the set points to the previous settings.

## Time Delay

ECHOLINE® includes an adjustable "stand alone" time delay to prevent intermittent tripping due to brief transient upsets. When the unit senses a pressure outside the limits, the status LED will immediately turn red, but the relay will not open for a pre-selected time delay. The time delay will reset to zero if the process pressure returns to within the limits during the transient conditions. This feature provides a degree of "fault tolerance" for exhaust flow interlock applications. The time delay is field settable through a jumper located on the rear of the enclosure for 1, 10, 20 or 30 seconds.

## ECHO Diagnostics

The ECHO function is an internal electronic check of certain circuit parameters. In the event of an internal failure, the ECHO output relay immediately opens to communicate the fault condition and the unit display goes blank. The electromechanical output relay has isolated contacts that monitor the circuit in real time.

# SPECIFICATIONS



<b>Indicating Pressure Ranges</b>	0.2 to 20" WC (see model chart)
<b>Display</b>	3½ digit, 0.30" high red LED
<b>Alarm Set Point Range</b>	Independently set high and low limits, 5 to 95% of indicating range
<b>Reset</b>	Alarm condition will remain until front panel reset button is pressed, and pressure is within limits
<b>Calibration</b>	Field adjustable zero via front panel screw adjustment
<b>Accuracy</b>	1% of range @ 20° C
<b>Switch and ECHO Outputs</b>	Electro-mechanical relay, SPDT, Form A Dry Contacts
<b>Relay Rating</b>	1.0A @ 30 VDC, resistive
<b>Status LEDs</b>	Green in normal state, red in alarm state
<b>Time Delay</b>	1, 10, 20, 30 seconds. Factory set at 10 seconds. Changeable via rear panel jumper.
<b>Analog Output (optional)</b>	4-20 mA, non-isolated, current sinking. Maintenance Mode feature disabled. 0 - 10 VDC
<b>Overpressure</b>	± 14.5 psi (8" WC and above), ± 80" WC (under 8" WC)
<b>Pressure Connection</b>	Push-to-connect fitting(s) for 0.25" O.D. tubing or dual barbed fitting for 0.170" I.D. hose
<b>Media</b>	Dry air, or inert non-conductive gas
<b>Operating Ambient Temperature</b>	0 to 40°C
<b>Enclosure</b>	½th DIN 43700, panel mounted polycarbonate, plastic
<b>Wiring</b>	Plugable terminal block, 18-26 AWG, DSub (9 pin) connector
<b>Weight</b>	7 oz (200 g) maximum
<b>Power</b>	12-24 VDC, 1.4 Watts

# APPROVALS

**CE** Conformance to S2-0200 SEMI standards  
EN61326-1:1997 Electromagnetic compatibility

UL Recognized Component – **Complies with the requirement of UL 991.**

# MODEL CHART

Model		Range / Units*	Minimum Set Pressure	Proof Pressure	Burst Pressure
LDP0.2	WC	0.2" x 0.001" WC	.002" WC	± 80" WC	120" WC
LDP0.5	WC	0-0.5" x 0.001" WC	0.03" WC	± 80" WC	120" WC
LDP1	WC	0-1" x 0.01" WC	0.05" WC	± 80" WC	120" WC
LDP2	WC	0-2" x 0.01" WC	0.10" WC	± 80" WC	120" WC
LDP5	WC	0-5" x 0.01" WC	0.3" WC	± 80" WC	120" WC
LDP10	WC	0-10" x 0.1" WC	0.5" WC	± 14.5 psig	20 psig
LDP20	WC	0-20" x 0.1" WC	1.0" WC	± 14.5 psig	20 psig
LDP100	MW	0-100 x 0.1 mm WC	5 mm WC	± 80" WC	7 psig
LDP50	P	0-50 Pascal x 0.1 Pascal	3 Pa	± 80" WC	120" WC
LDP100	P	0-100 Pascal x 1 Pascal	5 Pa	± 80" WC	120" WC
LDP500	P	0-500 Pascal x 1 Pascal	25 Pa	± 80" WC	120" WC
LDP1000	P	0-1000 Pascal x 1 Pascal	50 Pa	± 80" WC	120" WC
LDP2000	P	0-1999 Pascal x 1 Pascal	100 Pa	± 80" WC	120" WC
LDP10	KP	0-10 KPa x 0.01 KPa	0.50 KPa	± 30 psig	45 psig

\* For user selectable scale (WC to Pa), consult factory

\* For alternate units of measurement, consult factory

## DIMENSIONAL DRAWINGS

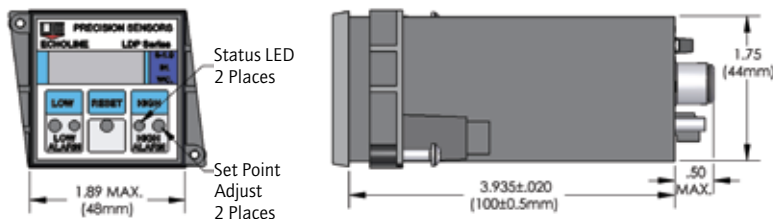

### Optional Clear Watertight Cover

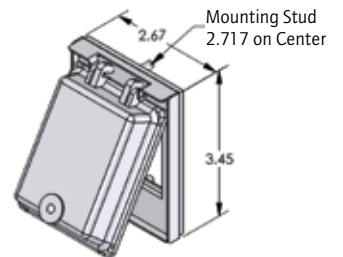

### Back View Single Port Gage Pressure

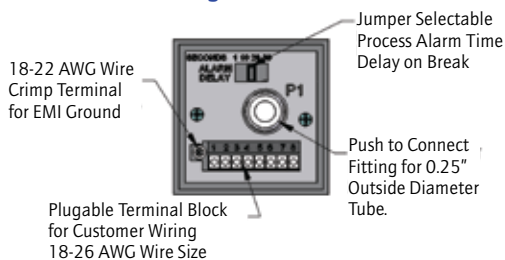

### Back View Dual Port Differential Pressure

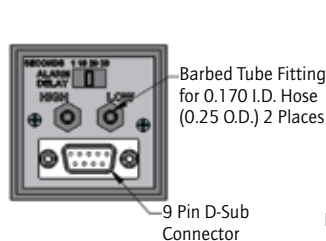

### Optional Retrofit Mounting Plate

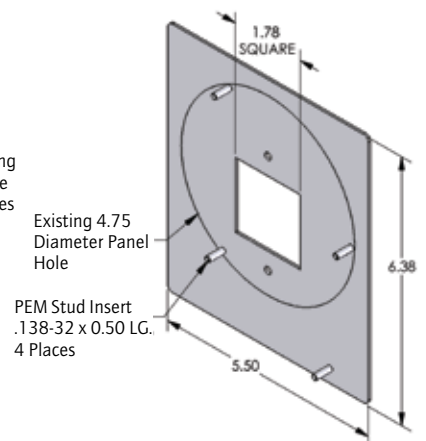

# HOW TO ORDER

Create a part description by using the system below. The part description will follow this form.

**LDP**                      **1 WC**                      —                      **N**                      **M**                      **C**                      **M05**  
 Type                      Setting                                           Pressure                      Standard                      Accessory                      Options  
    Range                      Connection                      Pressure

	CODE	DESCRIPTION	LDP	1 WC	N	M	C	M05
<b>Type</b>	LDP	Low Differential Pressure						
<b>Setting Range</b>								
	<b>Inches of Water Column</b>							
	0.2WC	0 - 0.2" WC						
	0.5WC	0 - 0.5" WC						
	1WC	0 - 1" WC						
	2WC	0 - 2" WC						
	5WC	0 - 5" WC						
	10WC	0 - 10" WC						
	20WC	0 - 20" WC						
	<b>Millimeters of Water Column</b>							
	100MW	0 - 100 MW						
	<b>Pascal</b>							
	50 P	0 - 50 Pascal						
	100 P	0 - 100 Pascal						
	500 P	0 - 500 Pascal						
	1000 P	0 - 1000 Pascal						
	2000 P	0 - 1999 Pascal						
	10 KPa	0 - 10 KPa						
<b>Pressure Connection</b>								
	N	Single push-to-connect for "Negative" Pressure						
	P	Single push-to-connect for "Positive" Pressure						
	D	Dual barbed tube for "Differential" Pressure						
<b>Standard Features</b> (only one can be selected)								
	M	Maintenance Mode						
	A	4 - 20 mA Analog Output						
	V	0-10 VDC Analog Output						
<b>Accessory</b>								
	C	Clear watertight cover (when ordering separately, specify p/n 9728)						
	P	Retrofit mounting plate (when ordering separately, specify p/n 9729)						
<b>Options</b>								
	M01	Non-latching alarm (automatic reset)						
	M02	6 mm Metric push-to-connect fitting, use with 'N' pressure connection only						
	M03	Positive pressure alarm						
	M05	D Sub connector (9 pin)						
	M07	No low alarm						
	M08	No high alarm						

The specified example denotes a 0 to 1" WC ECHOLINE® with a single "negative" pressure port, maintenance mode option, watertight cover and D Sub connector.



**UNITED ELECTRIC  
CONTROLS**

**Precision Sensors Division**

50 Seemans Lane  
 Milford, CT 06460 USA  
 Telephone: 203.877.2795 Fax: 203.877.8752  
 Email: sales@precisionsensors.com  
 www.precisionsensors.com



BHA2K1008 STA-AD1